

**AUX**

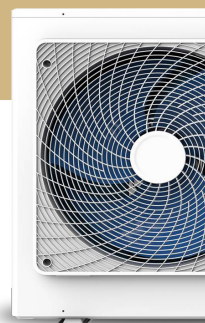

# HEAT PUMPS

## CATALOGUE





# AUX

## AIR CONDITIONER

# CONTENTS

About the AUX group	4
Sustainable development	8
Energy from nature	10
How does a heat pump work?	12
Application	14
Why choose AUX heat pump?	16
Features and functions	18
Technical specifications	26
Technical drawings	30





**36 YEARS**  
OF EXPERIENCE

**180**  
COUNTRIES

**11**  
BASES

# AUX

## AIR CONDITIONER

## ABOUT AUX BRAND

### A NEW QUALITY LEVEL

The AUX Group, present on global markets for 36 years, is considered one of the leading manufacturers in the following sectors: real estate, finance, electronics and smart household appliances. It has advanced, fully automated production facilities, research and development centres, and highly qualified staff. HVAC systems are major branch of the group's business, and the continuous and dynamic growth of sales volume has placed the AUX brand among the top three brands in the Chinese air conditioning industry. The AUX group pays a lot of attention to sustainable development, with focus on renewable resources preserving quality lifestyle of present and future generations. In laboratories, patented technologies are constantly being developed, optimised, and new ecological, energy-efficient and reliable solutions are introduced. The concept of sustainable development goes hand in hand with caring for human health and improving the quality of the air we breathe.

The AUX logo is displayed in a bold, white, sans-serif font against a dark blue background.

---

*Millions of users worldwide  
trust AUX brand*

”

# ABOUT AUX BRAND PRODUCTS

## ROOM AIR CONDITIONERS

AUX room air conditioners line includes 8 unique wall-mounted models. All units feature sophisticated styling and the widest range of features in their range.

## COMMERCIAL AIR CONDITIONERS

AUX air conditioning systems are the perfect solution for commercial buildings. Wall-mounted, cassette, duct, and floor/ceiling units allow designing complete and discreet air conditioning systems in every room.

## MULTI AIR CONDITIONERS

The AUX brand offers multi-split air-conditioning solutions, which are becoming more and more popular in Poland. Multi-split is ideal for homes, apartments, shops, small hotels, and commercial facilities.

## ARV SYSTEMS

ARV6 is the latest generation system from AUX. Highly technologically advanced devices are an ideal solution for commercial, office, hotel, and residential buildings (ARV6 Mini).

## HEAT PUMPS

Air-to-water heat pumps are a novelty that is a direct response to the changing needs of the market. The AUX group has designed intelligent and reliable devices that provide energy-saving and complete home heating systems.



---

# 5

RESEARCH AND  
DEVELOPMENT  
CENTRES

---

---

# 30

THOUSAND  
EMPLOYEES



**AUX**

---

*AUX is an expert in providing  
energy saving solutions*

”



”

---

*AUX cares about the quality of the air  
you breathe*

# SUSTAINABLE DEVELOPMENT

The AUX Group, as one of the leading manufacturers of advanced air conditioning and heat pump systems, approaches sustainable development very seriously. Caring for the environment is one of the major aspects of sustainable development. The policy of the AUX brand is based on the idea of careful exploitation of natural resources, so that both present and future generations can live in prosperity. Teams of qualified engineers working at AUX R&D centres around the world invent energy-saving, intelligent and ecological tech solutions, which are used in production processes to support the concept of sustainable development and provide high-quality and clean air.

## CARING FOR A BETTER TOMORROW



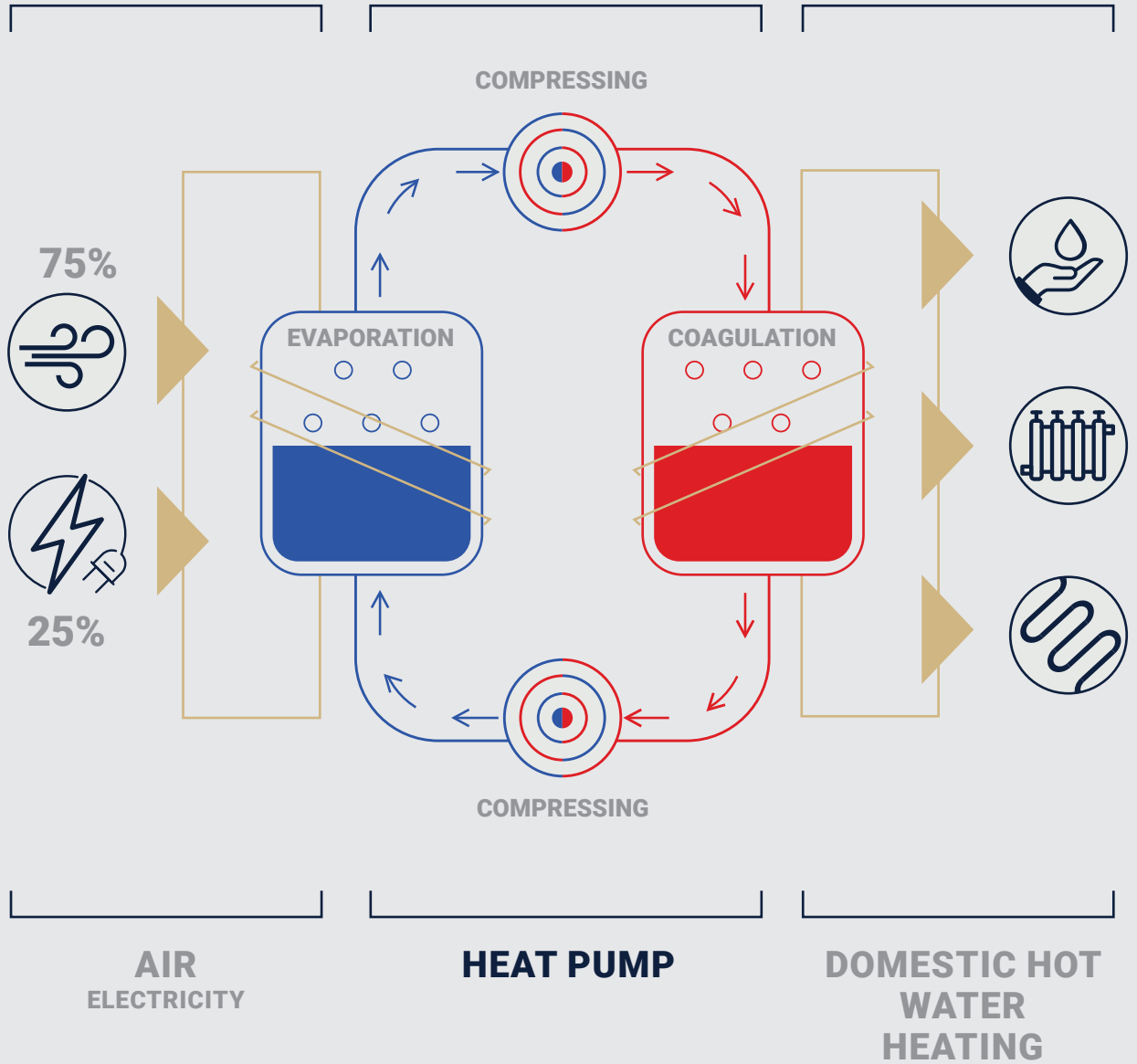

# AUX



## ENERGY FROM NATURE

A heat pump uses as much as 75% of free energy available from the air, the remaining 25% comes from electricity. It means that the device collects heat that is present in the air and transfers it to the building consuming a small amount of electricity. The energy efficiency of a heat pump is determined by the coefficient of performance (COP), which determines the ratio of the amount of heat supplied to the amount of electricity consumed. The higher the COP, the greater the energy efficiency. The higher the energy efficiency indicator, the higher the efficiency and consequently - the savings. A heat pump is one of the most economical and environmentally friendly heating systems.

---

*In AUX heat pumps 75% of free energy  
comes from the environment*



# HOW DOES A HEAT PUMP WORK?

The vast majority of air-to-water heat pumps are classified as renewable energy sources and are currently considered the most efficient heating solution. An air-to-water heat pump is a device that uses heat accumulated in the air for heating or cooling space and domestic hot water system. Against all appearances, the way a heat pump works is not complicated and it uses a well-known mechanism that can be found in refrigerators for example. The most important parts of a heat pump are the compressor, expansion valve, condenser, and evaporator. The whole process is possible thanks to the physical properties of the refrigerant. Refrigerant is a liquid that circulates in the closed loop system. It boils at low pressure and low temperature and this way it absorbs heat from the environment. Then pressure and temperature are increased in the system by a compressor and the refrigerant changes into gas, next it moves to a condenser and releases heat to the system. Afterwards, liquid refrigerant passes through the expansion valve where the pressure and temperature drop and the process starts again. If a heat pump provides cooling, the process is reversed - refrigerant absorbs heat from the water and removes it outside.

**HEAT  
PUMP**  
IS THE BEST  
CHOICE!



## The most important factors defining heat pump efficiency



### COP

Coefficient of Performance

Coefficient of performance, which determines the ratio of the amount of thermal energy supplied to the heat pump to the amount of energy consumed by it. If the COP of a heat pump is 5, it means that the device consumes 1kW of electricity to provide 5kW of heat.

### SCOP

Seasonal Coefficient of Performance

Seasonal coefficient of performance allows you to calculate the amount of electricity consumed by a device during the year or heating season. It allows calculating easily the cost of heating a building with a heat pump.

### EER

Energy Efficiency Ratio

Coefficient of performance determines the ratio of the amount of cooling energy supplied to a heat pump to the amount of energy consumed by it. If the EER for of heat pump is 5, it means that the device consumes 1kW of electricity to provide 5kW of cooling.

### SEER

Seasonal Energy Efficiency Ratio

Coefficient of performance determines the ratio of the amount of cooling energy supplied to a heat pump to the amount of energy consumed by it. If the EER form of a heat pump is 5, it means that the device consumes 1kW of electricity to provide 5kW of cooling.

THE HIGHER SCOP AND SEER,  
THE LOWER ELECTRICITY BILLS

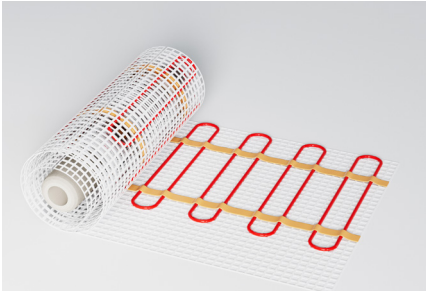

**Floor heating**

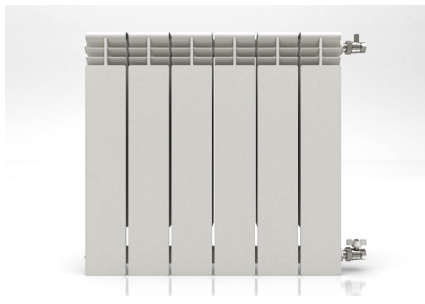

**Radiator**



**Fan coil unit**



# HEAT PUMP WORKS WITH **HEAT RECEIVERS**

Air-to-water heat pumps work with the following heat receivers: fan coil units, radiators, or floor heating systems. However, the use of low-temperature heat receivers works best in terms of efficiency. Radiant heating is characterized by large surface and as a consequence, there is no need for high temperature in the system contrary to compact heat sources.





# WHY CHOOSE AUX HEAT PUMP?



## Complete heating system

It heats, cools the building and supplies domestic hot water



## Safety

No risk of fire, explosion or carbon monoxide poisoning



## Versatile use

Dedicated to newly built and additionally insulated buildings



## Easy and quick assembly

The approximate installation time carried out by an experienced company is 1 to 3 days



### Maintenance-free

There is no need to clean, start a fire, or constant monitoring of the unit



### Ecology

Heat pumps do not emit harmful substances into the environment



### Peace and quiet

The quiet operation guarantees high comfort



### Aesthetics

No need to install radiators which often affect the aesthetics of the interior



### Savings

Free energy obtained from the air and the possibility of connecting to a photovoltaic system



### Long lifespan

It is estimated that the average lifespan of a heat pump is 20 years

# FEATURES AND FUNCTIONS OF AUX HEAT PUMP



Surface heating



R32 refrigerant



Domestic hot water up to 60°C



Inverter technology



Energy efficiency A+++



Fast Domestic Hot Water



Sterilisation at 65°C



Water temperature auto-adaptation



ECO mode



Holiday mode



Quiet operation



SG Ready



Safety



Certificates



Emission-free



Maintenance-free



Quick installation



Versatile use



Low operating costs



Wi-Fi module

# AUX



## Surface heating

A heat pump works with low-temperature floor, wall, and ceiling heating systems

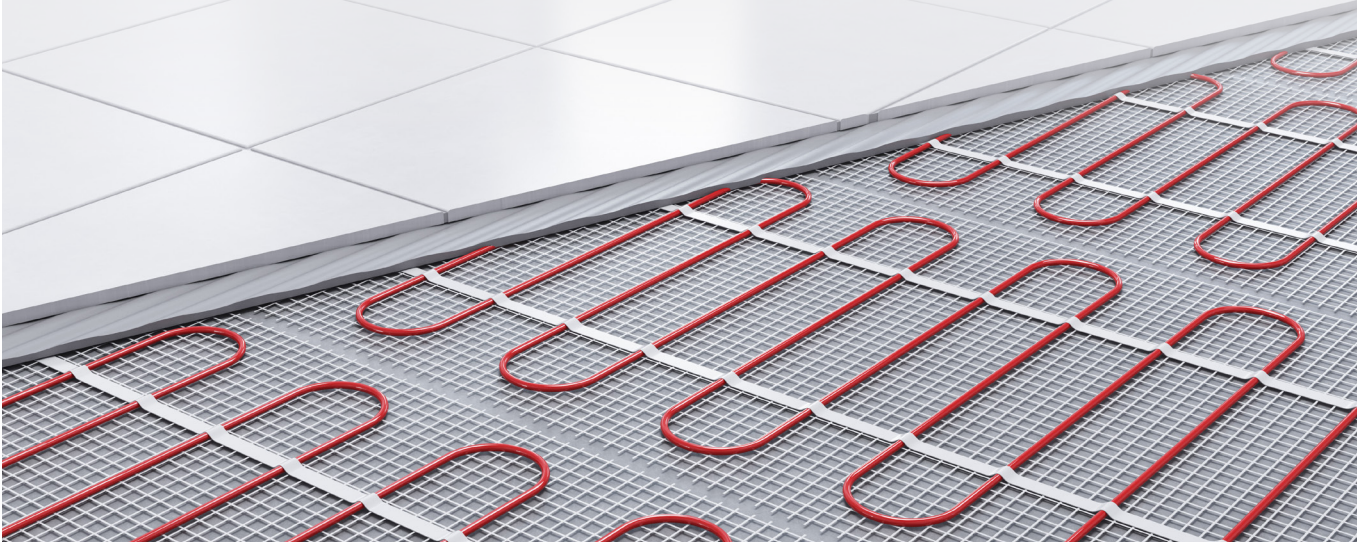

## R32 refrigerant

It uses the most environmentally friendly R32 refrigerant currently available on the market



*AUX develops and implements innovative technologies*

## Domestic hot water up to 60°C



Provides domestic hot water reaching a temperature up to 60°C.



## Inverter technology



Inverter technology allows smooth control of efficiency without lowering the capability of the device



## Energy efficiency A+++

A +++ energy efficiency is a guarantee of energy saving



## Fast Domestic Hot Water

The Fast DHW mode will heat up the water in no time



## Sterilisation at 65°C

High sterilization temperature provides 99% effectiveness in eliminating legionella bacteria that are able to multiply in hot water tanks when water is not used for a long time



## Water temperature auto-adaptation

The heat pump defines and sets the optimum water temperature for the highest comfort



## ECO mode



ECO mode saves up to 50% of energy



## Holiday mode



The holiday mode protects the device against possible damage caused by low temperature, i.e. frost

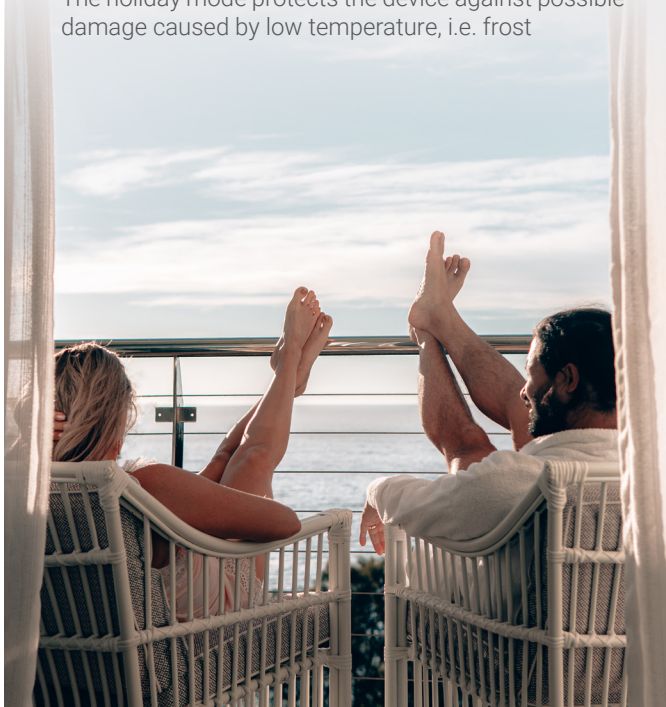

## Quiet operation



Quiet operation of the outdoor unit with the noise level below 45dB and the indoor unit below 31dB



## SG Ready



Heat pumps marked with SG Ready label are equipped with control system that allows to connect a single heat pump into a smart grid





## Safety

No risk of explosion or release of toxic carbon monoxide while heating a house with a heat pump. No carbon dioxide is released during the operation of a heat pump



## Certificates

The AUX heat pump is KEYMARK certified confirming the compliance of products and services with European standards and hygienic certification.



## Emission-free



A heat pump does not emit any pollutants into the environment which makes it an ecological alternative to traditional heating methods



## Maintenance-free



A heat pump is almost a maintenance-free system so it saves a lot of time



## Quick installation



Installation of an air-source heat pump is relatively quick and easy. It usually takes 2 to 3 days



## Versatile use



Heat pump works with various heat receivers (floor heating, radiators, fan coil units) and it can operate in combined systems with other heat sources such as gas furnaces or electric heaters





## Low operating cost

The operating cost of a heat pump is really low. This is primarily due to the high energy efficiency of this device

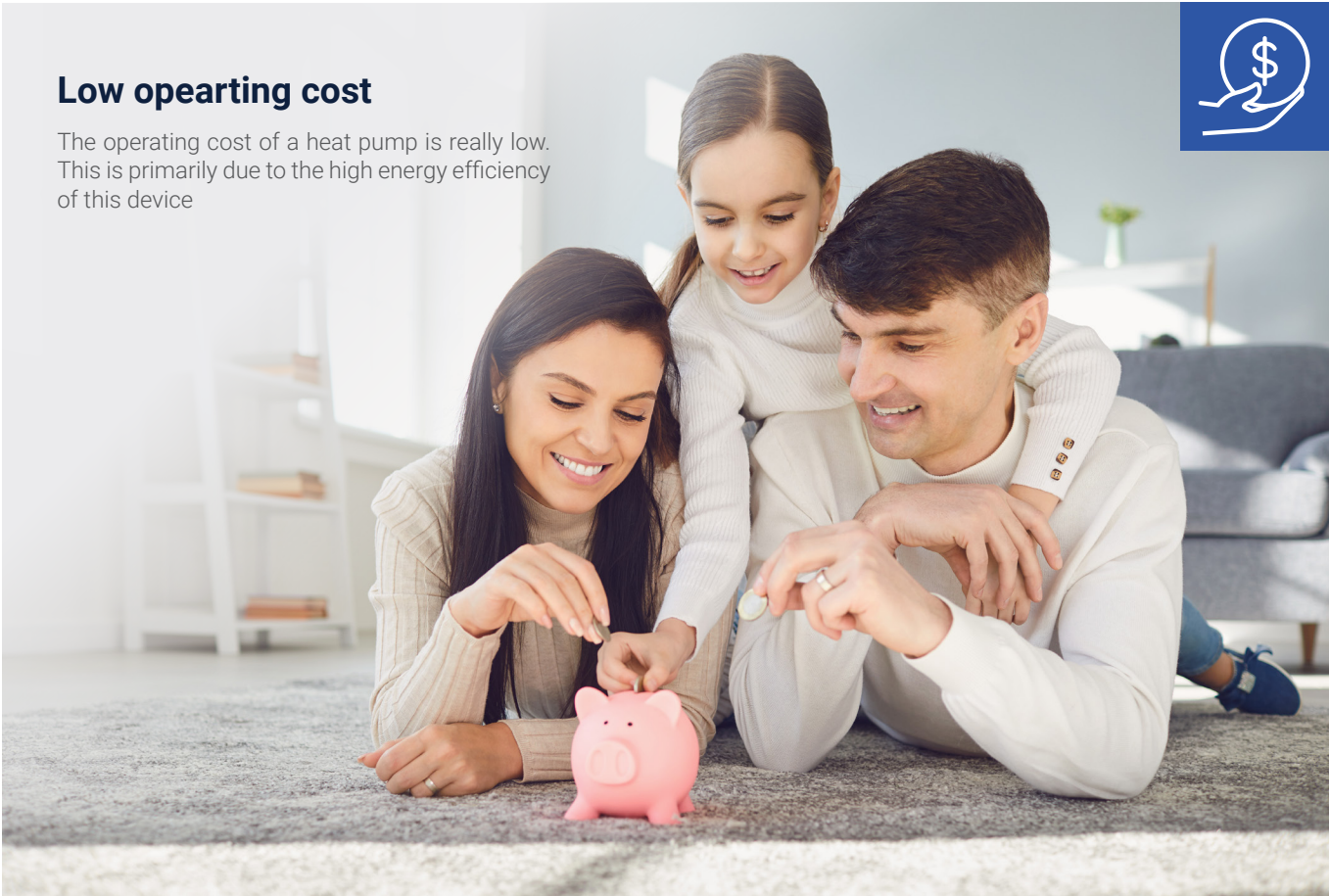

## Wi-Fi module

Wi-Fi module provides easy and convenient control with the app

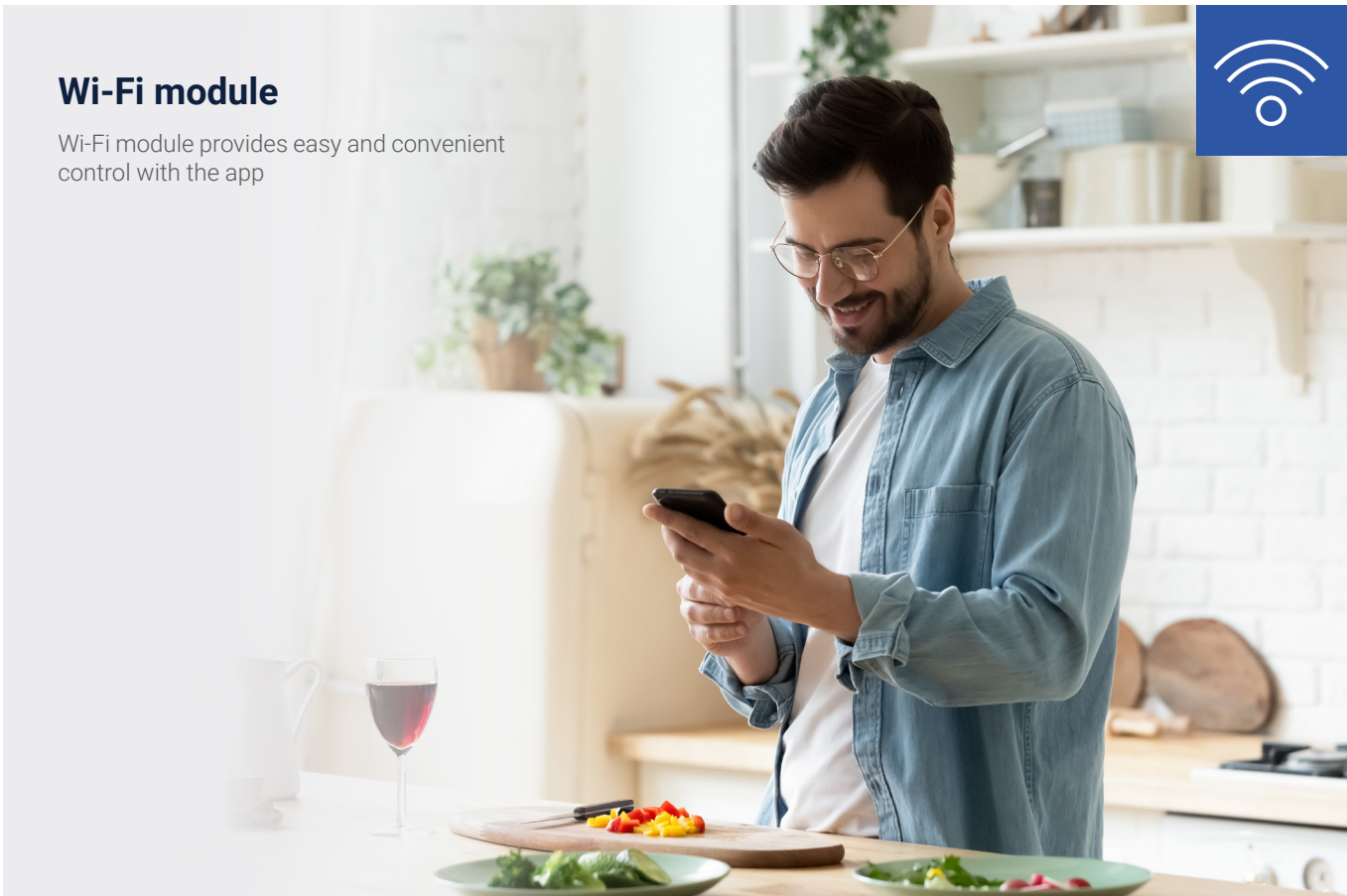

# TECHNICAL SPECIFICATIONS



Model name			ACHP-H04/4R3HA	ACHP-H06/4R3HA	ACHP-H08/4R3HA
<b>Outdoor unit</b>			<b>ACHP-H04/4R3HA-O</b>	<b>ACHP-H06/4R3HA-O</b>	<b>ACHP-H08/4R3HA-O</b>
<b>Indoor unit</b>			<b>ACHP-H04/4R3HA-I</b>	<b>ACHP-H06/4R3HA-I</b>	<b>ACHP-H08/5R3HA-I</b>
<b>Heating (A7/W35) (1)</b>	<b>Capacity</b>	<b>kW</b>	4,3	6,25	8,4
	<b>Power consumption</b>	<b>kW</b>	0,83	1,3	1,62
	<b>COP</b>		5,2	5	5,2
<b>Heating (A7/W55) (2)</b>	<b>Capacity</b>	<b>kW</b>	4,36	6,4	8,3
	<b>Power consumption</b>	<b>kW</b>	1,47	2,13	2,60
	<b>COP</b>		2,96	3	3,19
<b>Cooling (A35/W18) (3)</b>	<b>Capacity</b>	<b>kW</b>	4,5	6,6	8,45
	<b>Power consumption</b>	<b>kW</b>	0,81	1,35	1,67
	<b>EER</b>		5,56	4,9	5,06
<b>Cooling (A35/W7) (4)</b>	<b>Capacity</b>	<b>kW</b>	4,75	7,05	7,45
	<b>Power consumption</b>	<b>kW</b>	1,40	2,35	2,20
	<b>EER</b>		3,4	3	3,39
<b>Seasonal Energy Efficiency Class: Heating (6)</b>	<b>LWT 35°C</b>		A+++	A+++	A+++
	<b>LWT 55°C</b>		A++	A++	A++
<b>SCOP (6)</b>	<b>LWT 35°C</b>		4,86	4,96	5,22
	<b>LWT 55°C</b>		3,32	3,53	3,37
<b>Power</b>	<b>Outdoor unit</b>	<b>V~/Hz</b>	220-240/1/50	220-240/1/50	220-240/1/50
	<b>Indoor unit</b>	<b>V~/Hz</b>	220-240/1/50	220-240/1/50	380-415/3/50
<b>Maximum Circuit Breaker</b>	<b>A</b>		18	18	19



ACHP-H10/4R3HA	ACHP-H12/5R3HA	ACHP-H14/5R3HA	ACHP-H16/5R3HA
<b>ACHP-H10/4R3HA-O</b>	<b>ACHP-H12/5R3HA-O</b>	<b>ACHP-H14/5R3HA-O</b>	<b>ACHP-H16/5R3HA-O</b>
<b>ACHP-H10/5R3HA-I</b>	<b>ACHP-H12/5R3HA-I</b>	<b>ACHP-H14/5R3HA-I</b>	<b>ACHP-H16/5R3HA-I</b>
10	12,2	14,5	16,1
2	2,44	3,08	3,57
5	5	4,71	4,51
10	12	14	16,1
3,23	3,86	4,67	5,53
3,1	3,11	3	2,91
10	12	13,6	15
2,08	3	3,78	4,41
4,8	4	3,6	3,4
8,3	11,7	12,8	14
2,52	4,3	5,00	5,7
3,3	2,75	2,56	2,46
A+++	A+++	A+++	A+++
A++	A++	A++	A++
5,2	4,82	4,71	4,63
3,5	3,46	3,48	3,43
220-240/1/50	380-415/3/50	380-415/3/50	380-415/3/50
380-415/3/50	380-415/3/50	380-415/3/50	380-415/3/50
19	14	14	14

(1) Outdoor temperature 7°C DB, 85% R.H.; EWT 30°C, LWT 35°C  
 (2) Outdoor temperature 7°C DB, 85% R.H.; EWT 40°C, LWT 45°C  
 (3) Outdoor temperature 7°C DB, 85% R.H.; EWT 47°C, LWT 55°C  
 (4) Outdoor temperature 35°C DB, EWT 23°C, LWT 18°C  
 (5) Outdoor temperature 35°C DB, EWT 12°C, LWT 7°C  
 (6) Seasonal energy efficiency class measured under average climatic conditions  
 Relevant EU standards and regulations: EN14511; EN14825; EN50564; EN12102

Model name			ACHP-H04/4R3HA	ACHP-H06/4R3HA	ACHP-H08/4R3HA
<b>Outdoor unit</b>			<b>ACHP-H04/4R3HA-O</b>	<b>ACHP-H06/4R3HA-O</b>	<b>ACHP-H08/4R3HA-O</b>
<b>Indoor unit</b>			<b>ACHP-H04/4R3HA-I</b>	<b>ACHP-H06/4R3HA-I</b>	<b>ACHP-H08/5R3HA-I</b>
<b>Compressor</b>	<b>Type</b>	-	Double rotary DC inverter	Double rotary DC inverter	Double rotary DC inverter
<b>Outdoor unit fan</b>	<b>Motor type</b>	-	Brushless DC motor	Brushless DC motor	Brushless DC motor
	<b>Number of fans</b>	-	1	1	1
<b>Refrigerant type (R32)</b>	<b>Quantity</b>	<b>kg</b>	1,10	1,10	1,45
<b>Expansion valve type</b>		-	Electronic	Electronic	Electronic
<b>Cooling system</b>	<b>Liquid / gas pipe diameter</b>	<b>mm</b>	Φ9.52/15.9	Φ9.52/15.9	Φ9.52/15.9
	<b>Piping length min/max</b>	<b>m</b>	2/30	2/30	2/30
<b>Height difference in the system</b>	<b>Outdoor unit above/below</b>	<b>m</b>	20	20	20
<b>Sound pressure level (1m)</b>	<b>Outdoor unit</b>	<b>dB</b>	43	44	45
	<b>Indoor unit</b>	<b>dB</b>	28	28	29
<b>Net dimensions (LxHxW)</b>	<b>Outdoor unit</b>	<b>mm</b>	350×700×900	350×700×900	395×805×970
	<b>Indoor unit</b>	<b>mm</b>	420×790×270	420×790×270	420×790×270
<b>Packaging dimensions (LxHxW)</b>	<b>Outdoor unit</b>	<b>mm</b>	430×770×1020	430×770×1020	495×895×1105
	<b>Indoor unit</b>	<b>mm</b>	515×985×355	515×985×355	515×985×355
<b>Net/gross weight</b>	<b>Outdoor unit</b>	<b>kg</b>	51/55	51/55	65/69
	<b>Indoor unit</b>	<b>kg</b>	38/43	38/44	39/45
<b>Operation range at ambient temperatures</b>	<b>Cooling</b>	<b>°C</b>	10 ~ 48	10 ~ 48	10 ~ 48
	<b>Heating</b>	<b>°C</b>	-25 ~ 35	-25 ~ 35	-25 ~ 35
	<b>DHW</b>	<b>°C</b>	-25 ~ 43	-25 ~ 43	-25 ~ 43
<b>Water temperature range</b>	<b>Cooling</b>	<b>°C</b>	5 ~ 25	5 ~ 25	5 ~ 25
	<b>Heating</b>	<b>°C</b>	25 ~ 65	25 ~ 65	25 ~ 65
	<b>DHW</b>	<b>°C</b>	30 ~ 60	30 ~ 60	30 ~ 60

ACHP-H10/4R3HA	ACHP-H12/5R3HA	ACHP-H14/5R3HA	ACHP-H16/5R3HA
<b>ACHP-H10/4R3HA-O</b>	<b>ACHP-H12/5R3HA-O</b>	<b>ACHP-H14/5R3HA-O</b>	<b>ACHP-H16/5R3HA-O</b>
<b>ACHP-H10/5R3HA-I</b>	<b>ACHP-H12/5R3HA-I</b>	<b>ACHP-H14/5R3HA-I</b>	<b>ACHP-H16/5R3HA-I</b>
Double rotary DC inverter	Double rotary DC inverter	Double rotary DC inverter	Double rotary DC inverter
Brushless DC motor	Brushless DC motor	Brushless DC motor	Brushless DC motor
1	1	1	1
1,45	1,84	1,84	1,84
Electronic	Electronic	Electronic	Electronic
Φ9.52/15.9	Φ9.52/15.9	Φ9.52/15.9	Φ9.52/15.9
2/30	2/30	2/30	2/30
20	20	20	20
48	49	50	54
29	31	31	31
395×805×970	420×860×990	420×860×990	420×860×990
420×790×270	420×790×270	420×790×270	420×790×270
495×895×1105	530×880×1085	530×880×1085	530×880×1085
515×985×355	515×985×355	515×985×355	515×985×355
65/69	88/94	88/94	88/94
39/45	39/45	39/45	39/45
10 ~ 48	10 ~ 48	10 ~ 48	10 ~ 48
-25 ~ 35	-25 ~ 35	-25 ~ 35	-25 ~ 35
-25 ~ 43	-25 ~ 43	-25 ~ 43	-25 ~ 43
5 ~ 25	5 ~ 25	5 ~ 25	5 ~ 25
25 ~ 65	25 ~ 65	25 ~ 65	25 ~ 65
30 ~ 60	30 ~ 60	30 ~ 60	30 ~ 60

Model name		ACHP-H04/4R3HA	ACHP-H06/4R3HA	ACHP-H08/4R3HA	
Outdoor unit		ACHP-H04/4R3HA-O	ACHP-H06/4R3HA-O	ACHP-H08/4R3HA-O	
Indoor unit		ACHP-H04/4R3HA-I	ACHP-H06/4R3HA-I	ACHP-H08/5R3HA-I	
Water circulation	Water connection	inch	R1"	R1"	
	Safety valve setting	MPa	0,3	0,3	
	Minimum water flow	m³/h	0,36	0,36	
	Expansion vessel	Capacity	L	8	8
		Max water pressure	MPa	0,3	0,3
	Water exchange type	-	Flat plate	Flat plate	
	Electric flow-through heater	kW	3	3	
	Water pump head height	m	9,5	9,5	

# TECHNICAL DRAWINGS

## Outdoor unit 4 kW, 6 kW

ACHP-H04/4R3HA-O  
ACHP-H06/4R3HA-O

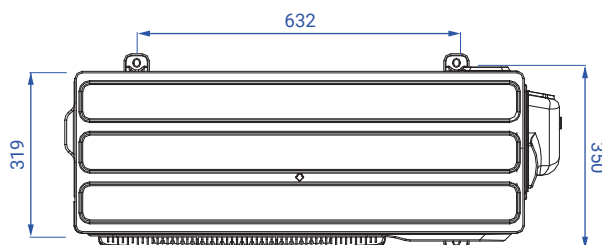
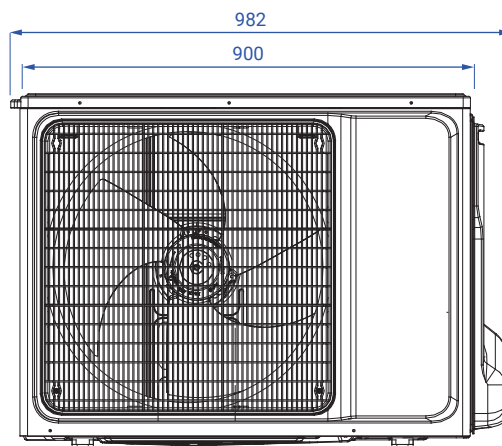
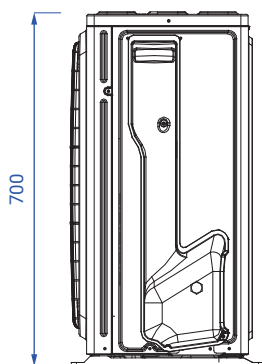

ACHP-H10/4R3HA	ACHP-H12/5R3HA	ACHP-H14/5R3HA	ACHP-H16/5R3HA
<b>ACHP-H10/4R3HA-O</b>	<b>ACHP-H12/5R3HA-O</b>	<b>ACHP-H14/5R3HA-O</b>	<b>ACHP-H16/5R3HA-O</b>
<b>ACHP-H10/5R3HA-I</b>	<b>ACHP-H12/5R3HA-I</b>	<b>ACHP-H14/5R3HA-I</b>	<b>ACHP-H16/5R3HA-I</b>
R1"	R1"	R1"	R1"
0,3	0,3	0,3	0,3
0,36	0,6	0,6	0,6
8	8	8	8
0,3	0,3	0,3	0,3
Flat plate	Flat plate	Flat plate	Flat plate
9	9	9	9
9,5	9,5	9,5	9,5

**Outdoor unit  
8 kW, 10 kW**

ACHP-H08/4R3HA-O  
ACHP-H10/4R3HA-O

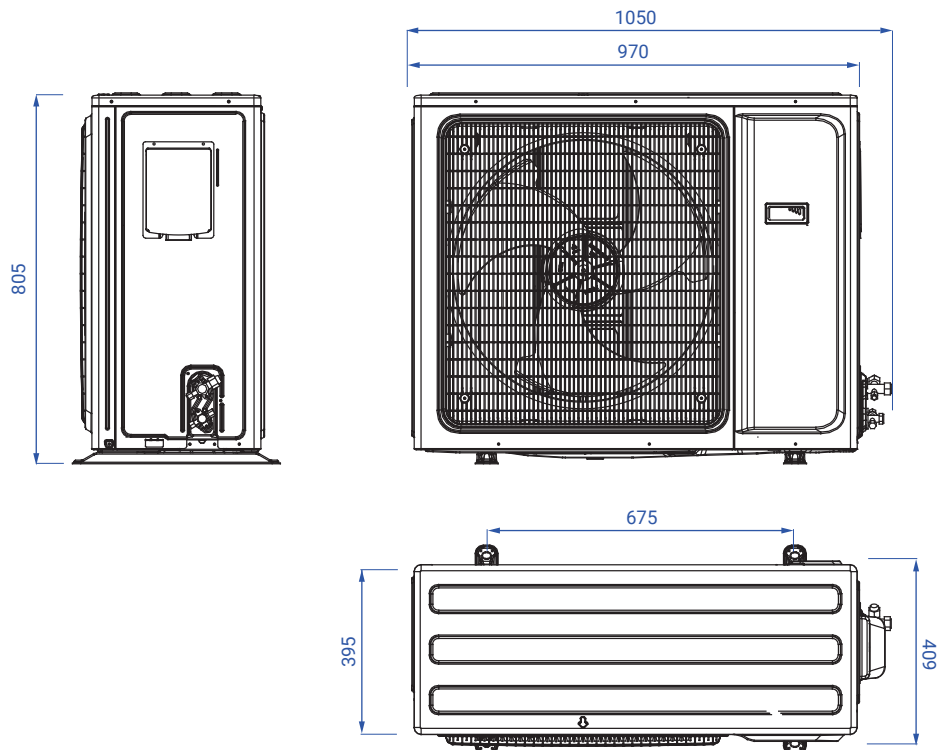

**Outdoor unit**  
**12 kW, 14 kW, 16 kW**

ACHP-H12/5R3HA-O  
 ACHP-H14/5R3HA-O  
 ACHP-H16/5R3HA-O

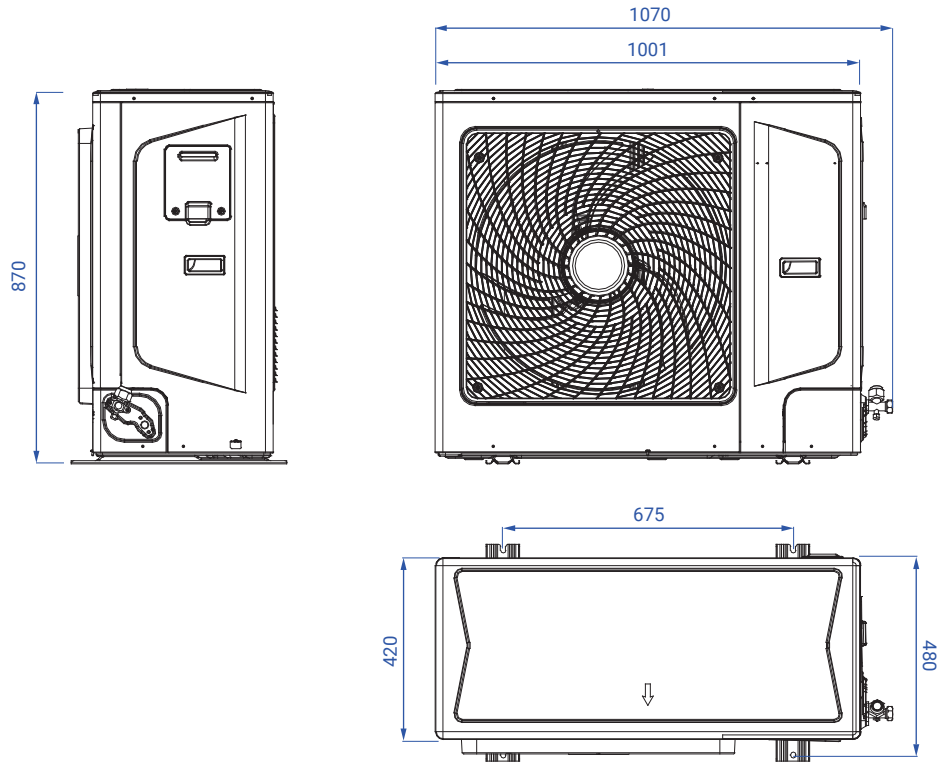

**Indoor unit**

ACHP-H04/4R3HA-I  
 ACHP-H06/4R3HA-I  
 ACHP-H08/5R3HA-I  
 ACHP-H10/5R3HA-I  
 ACHP-H12/5R3HA-I  
 ACHP-H14/5R3HA-I  
 ACHP-H16/5R3HA-I

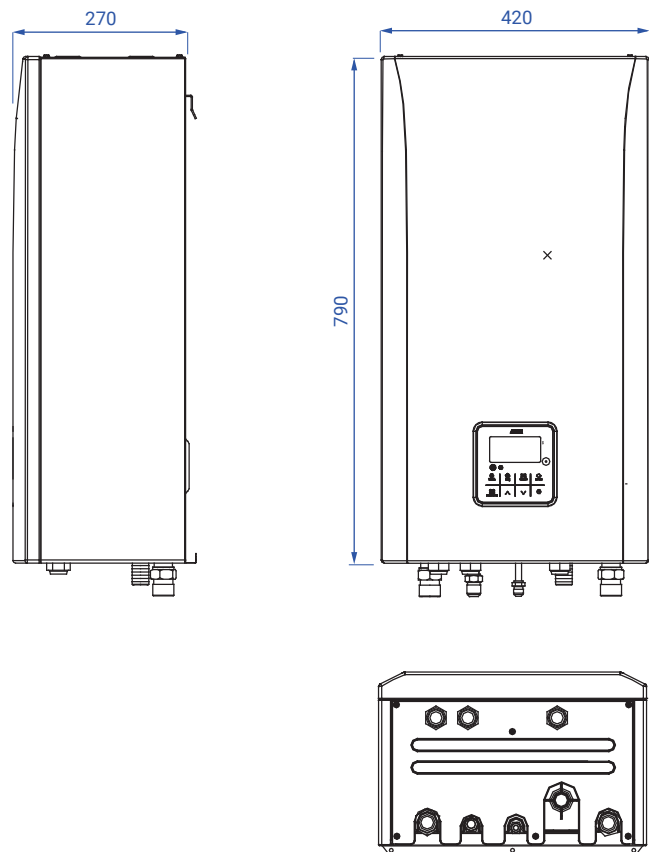



**AUX**

*AUX cares  
about the environment*



# YOUR TRUSTED **BUSINESS PARTNER**

We care about living conditions and well-being, which is why we offer a full range of air conditioning devices and systems dedicated to individual customers, small businesses, and large institutional customers.

# one



**Warranty  
service**



**Testing  
and booting  
devices**



**Designing  
and technical  
support**



**Deliveries**

**WWW.ONECONCEPT.RO**

We are **the exclusive** distributor of AUX  
brand in Poland!

See you at our branches

# WE ARE ALWAYS **FOR YOU**

We have supplied over a million air conditioners to our customers. For over 30 years we have been cooperating with world leaders in the production of air-conditioning devices. We are sure that we offer products and solutions of the highest quality and the latest technologies that meet high requirements in terms of energy efficiency, design, and ecology.

**AUX**  
AIR CONDITIONER

HEAT  
PUMPS

